

RGB

laser system

OPERATION MANUAL GALAXY 300



© Semiconductor Laser Development Ltd

All rights reserved

Version 1.0 / 19

Operation Manual

**PLEASE READ THIS MANUAL CAREFULLY BEFORE
ATTEMPTING TO USE THIS LASER.**

The manufacturer and the distributor do **NOT** take any responsibility - neither moral nor financial - for damages caused by improper use or misuse of our products. The owner/user is fully responsible for operating these products in accordance with laser safety regulations of the country where they are being used.

The laser is in Class – 3B!

Table of content

Foreword	4
Legal Notice	5
Pay attention to the following!	6
Laser Data	7
Fixture exterior view	8
Putting into operation	9
Placement and fastening of the equipment.....	9
Ethernet/DMX operation	10
Remotely controllable functions	12
Control menu	13
Operating environment.....	22
Maintenance	23
Technical parameters	24
DMX protocol	25
List of parts	26
Warranty	27



Foreword

Dear Customer,

Welcome to the users of Semiconductor Laser Development Ltd and thank you for purchasing our product. We are pleased to write these lines and provide you with items of information, as they mean that you get the results of a hard work our engineers have done in the last several years in order to satisfy your demands on the highest level. We have developed a new generation of laser equipment, which devices meet all the requirements in connection with their use, whether it is indoor or outdoor.

Our laser devices have been at our customers' disposal for quite a long time and accordingly, with the developments we had very high goals to reach. The task was not less than to develop our laser devices made of primary materials obtained from the most reliable sources even further, as it is our policy to satisfy the ever changing needs of an ever changing market. We are fully committed to design such devices, which can meet the highest requirements of our customers, who need the most up-to-date and sophisticated tools for their precision work. The work was hard, but we enjoyed the challenge and now we are happy to report that the mission has been accomplished - we have created a product which can be used for the realisation of every project.

An important part of our business philosophy is that our customers are among the most important members of the team of Semiconductor Laser Development Ltd. You are the ones who use our products and you are the ones to raise new demands in connection with our devices. These expectations are important motives to develop our company and our products. Driven by this force we are proud to provide you with excellent quality equipment made with the use of our quality assurance.

We are wishing you much success in your work with our products:

TEAM Semiconductor Laser Development Ltd



Legal Notice

- 1.) IT IS STRICTLY PROHIBITED and HAZARDOUS to cast the laser light either directly or indirectly to eyes!
- 2.) Having a stationary laser beam among people is NOT ALLOWED and DANGEROUS!
- 3.) As any contact between the laser light and skin may cause burns, it IS STRICTLY PROHIBITED and HAZARDOUS to cast the light to skin!
- 4.) According to the standards EN 60825-1 and IEC 60825-1 these pieces of equipment are in Class 3B. In 2001 the standard governing the safety of laser products in Europe (EN) and Internationally (IEC).
- 5.) Class 3B laser beams are capable of setting fire to materials onto which they are projected.
- 6.) Only qualified personnel is allowed to operate the device and one must use protective equipment such as safety goggles during its initial adjustments.
- 7.) During operation, those using the equipment must have a clear and full view of the device and the surface which laser beams are projected onto.
- 8.) Before putting the device into operation, information must be obtained about all the applicable rules and provisions of law in force in the country (where the work is done). These rules and provisions of law are to be obeyed in every country!
- 9.) It may be possible that there are several rules and safety regulations in a country or a region (where the device is to be used). In such a case, the stricter ones are to be obeyed!
- 10.) After becoming familiar with the safety requirements of the given country you are advised to ask for installing the right safety equipment, as well.
- 11.) The manufacturer and the distributor do NOT take any responsibility - neither moral nor financial - for damages caused by improper use or hazardous operation. In such cases, the responsibility always lies upon the owner / user.
- 12.) Please note that some optical devices such as cameras, video projectors, and mobile phone cameras can be damaged if exposed to laser radiation.
- 13.) Not reading these items of warning or not giving due attention to them cannot be used as a reason to avoid responsibility.



Pay attention to the following!

- 1.) The product has an input to process DMX control signals and it can be operated with the use of a DMX protocol. Any other type of signal sources connected to the DMX input and output terminals can cause permanent damages! It is **STRICTLY PROHIBITED** to connect any other control signal to these terminals!
- 2.) **DO NOT CONNECT** supply voltage to the product different from the specified one, as it can cause permanent damages to the equipment!
- 3.) Using the device without protective grounding is **STRICTLY PROHIBITED** and **HAZARDOUS TO LIFE!**
- 4.) Any static discharge in the inner part of the equipment may cause permanent damage!
- 5.) Strong impacts or vibration may cause damages to the product! Accordingly, it is **STRICTLY PROHIBITED** to expose it to such impacts or vibration of high intensity.
- 6.) Only fasten the device at the points designed for this purpose! In every case safety mounting is to be used.
- 7.) There are apertures required for ventilation and airflow cooling on the top side of the device. It is **PROHIBITED** to obstruct or block any of the apertures preventing the free flow of air, because it may cause damages to the equipment.
- 8.) **WARNING!** Never open any of the modules in the equipment, as it is **NOT ALLOWED!** Opening a module causes the immediate termination of the warranty! The modules are closed in a sterile laboratory and in a pressurized cabin. Accordingly, opening a module may cause an irreparable malfunction of the device.
- 9.) The manufacturer and the distributor do **NOT** take any responsibility - neither moral nor financial - for damages caused by improper use. Furthermore, not obeying any of the above instructions or opening the device **CAUSES THE TERMINATION OF WARRANTY**. Repair is only allowed in professional repair shops



Laser Data

Uniquely fast and high accuracy closed loop multi-effect RGB laser beam moving head for standalone use or additional effect next to laser projectors.

It could also be used for fun and creative activity games.

It consists of a 300mW RGB module in a moving head design. The user can define safety zones and due to the loosed loop movement the laser switches off in case of loss of position. It also features key switch and remote interlock.

This laser entertainment system is rated as a Class 3B laser product and manufactured in accordance to IEC 60825-1:2014. Avoid eye or skin exposure to direct or scattered radiation. Wear protective goggles of suitable optical density if necessary.

The Galaxy 300 Series are Class-3B equipment. The sign stating it is on front of the laser.

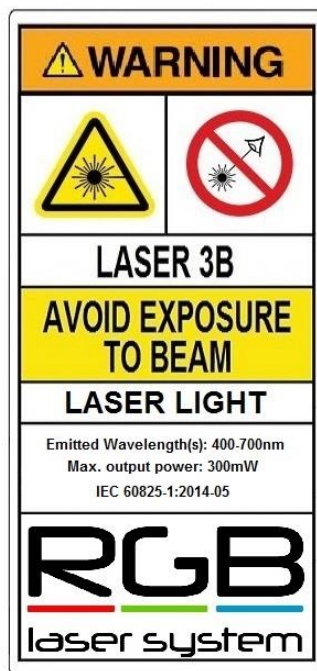

As the laser is sold all over the world, it is always the technical safety regulations of the country of operation which are to be obeyed. For your special request a device can be made with accessories in conformity with the technical safety regulations of a given country in force.

If the laser is operated in a situation where health or property injury may occur the operation must be stopped immediately.



Fixture exterior view

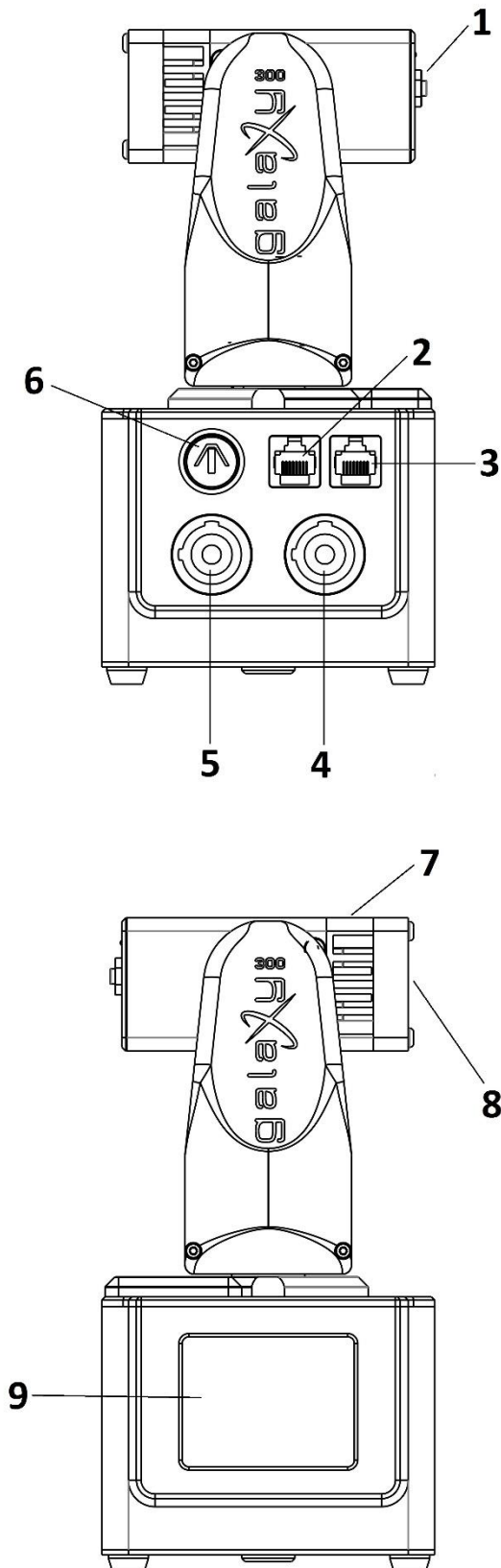

- 1** - Laser aperture
- 2** - RJ45
- 3** - RJ45
- 4** - Power out
- 5** - Power in
- 6** - Safety key switch
- 7** - Heat sink
- 8** - Cooling fan
- 9** - Display



Putting into operation

Placement and fastening of the equipment

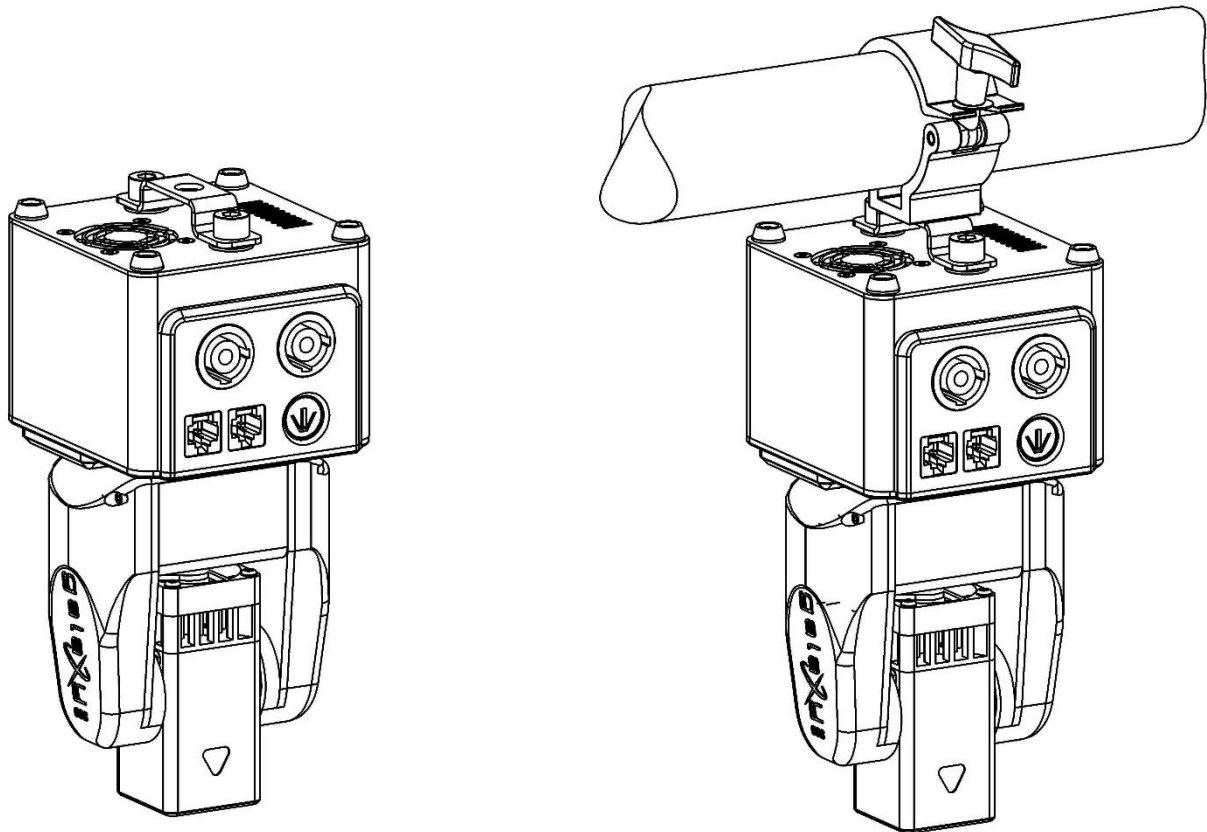

Ethernet/DMX operation

Connect the RJ45-input of the first fixture in the data chain with the network. Connect the DMX output of this fixture with the input of the next fixture until all fixtures are connected to the DMX chain.

Caution: At the last fixture, the DMX chain has to be terminated with a terminator.

On the next page, you can see an example for how a 32 PCS GALAXY 300 chain look like.



32 PCS GALAXY

MAX 8 PCS

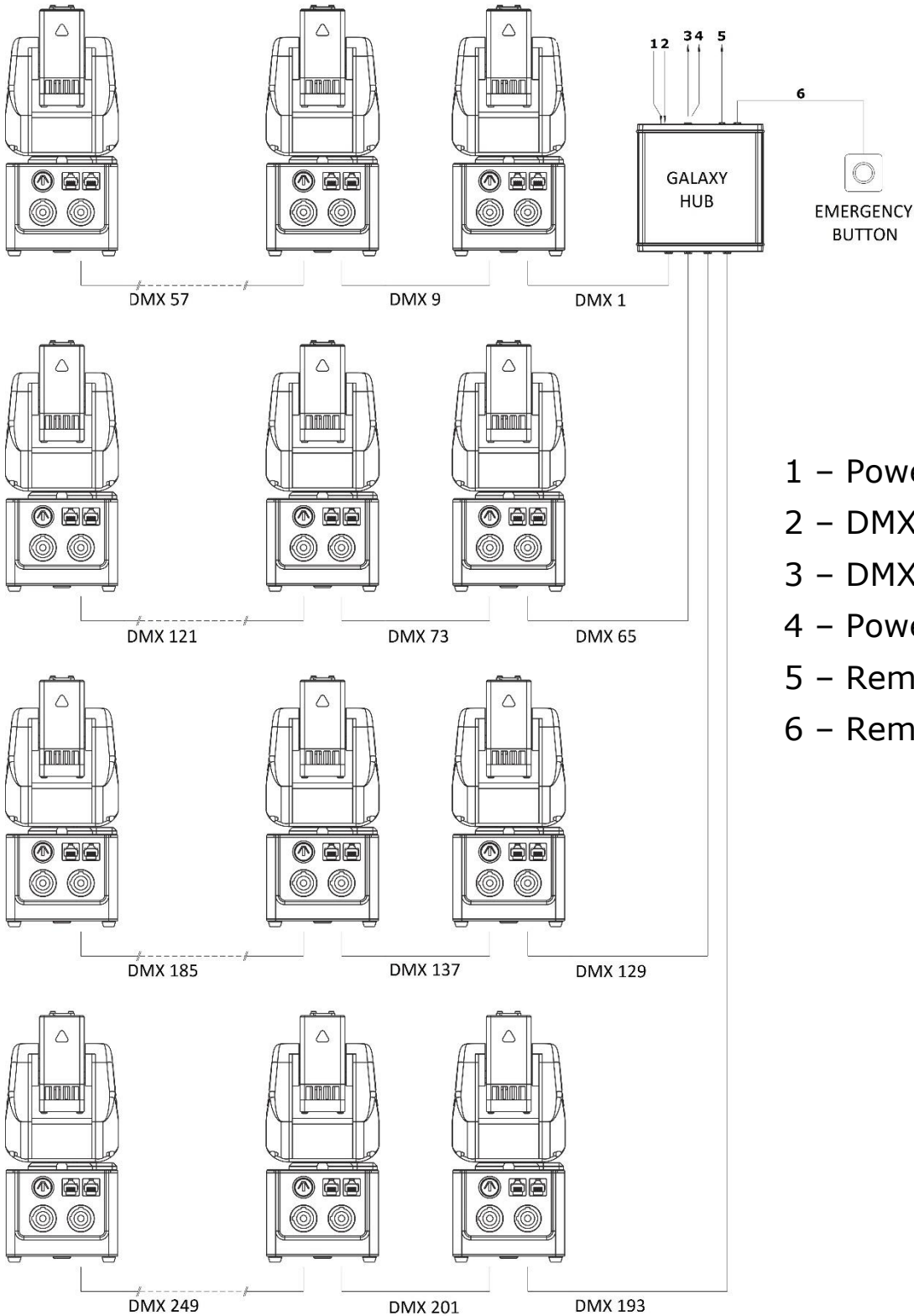

- 1 – Power IN
- 2 – DMX IN
- 3 – DMX OUT
- 4 – Power OUT
- 5 – Remote OUT
- 6 – Remote IN



Remotely controllable functions

Pan/Tilt

Precise pan/tilt movement due to built-in electronic motion stabilizer. The electronic motion stabilizer ensures precise position of the fixture's head during its movement and reduces its swinging when the truss shakes. Pan movement range: 540°, tilt movement range: 240°.

8-bit
16-bit

Tilt = 0 DMX
0 DMX

Tilt = 128 DMX
32767 DMX

Tilt = 255 DMX
65535 DMX

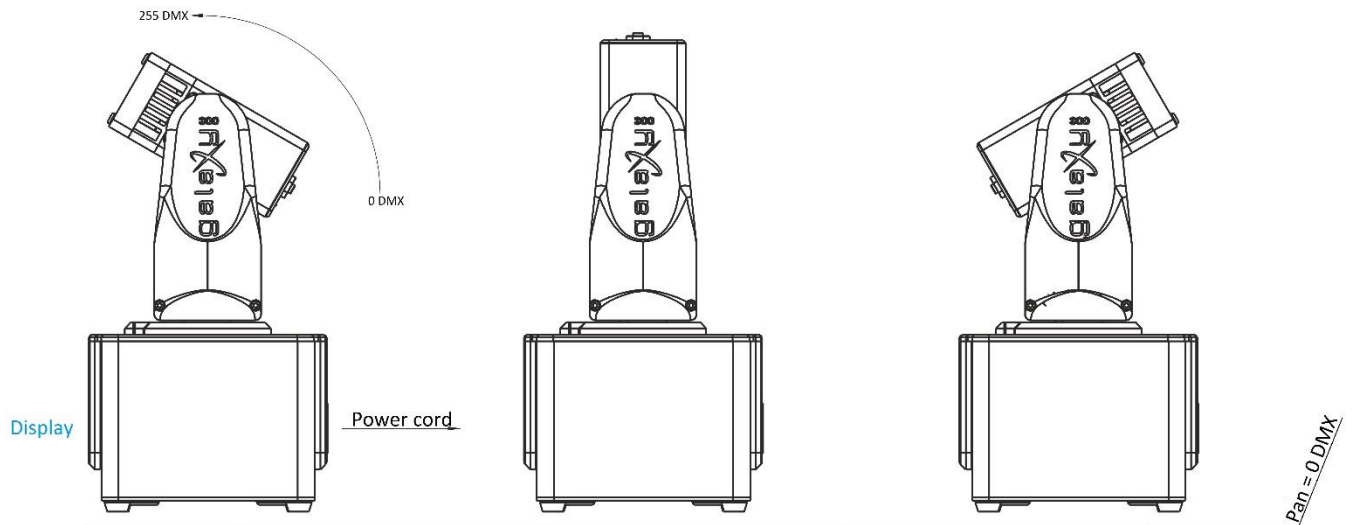

Tilt movement range: 240° Pan movement range: 540°

8-bit
16-bit

Pan = 0 DMX
0 DMX

Pan = 128 DMX
32767 DMX

Pan = 255 DMX
65535 DMX

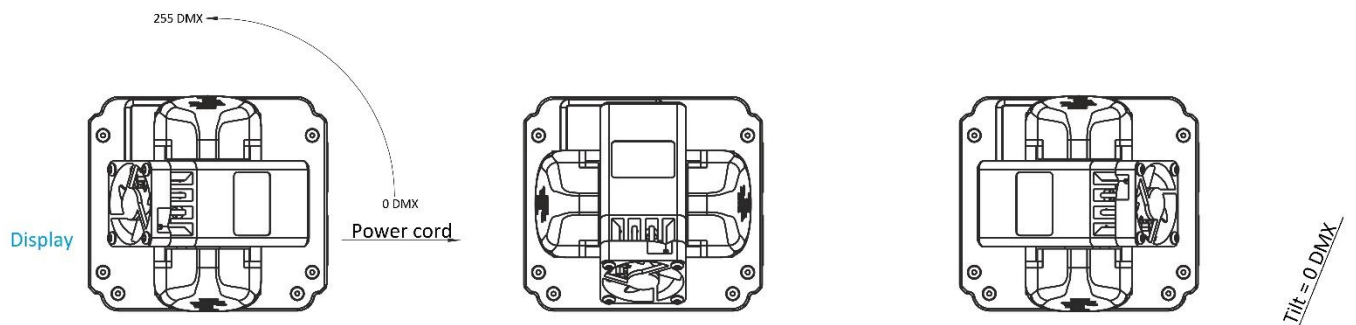

Dimmer unit

Smooth 0 - 100 % dimming is provided by the electronic control unit. This unit is also used for strobe effects with variable speed.



Control menu

The fixture's menu can be controlled directly by touching the screen.

After switching the fixture on, the touch screen shows the screen with the Semiconductor Laser Development logo:



Touch any part of the screen for 3 seconds to get into the GALAXY 300 menu.

After that, you can see 3 setup option (Laser, Moving, Control) and the Information tab.



Laser setup:

In this tab, you can setup the color balance and the laser's maximum output power.

Color balance



Max power



Moving setup:

In this tab, you can configure the direction, the max angle and the center of tilt/pan.

Direction

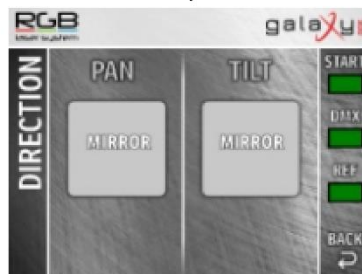

Max angle

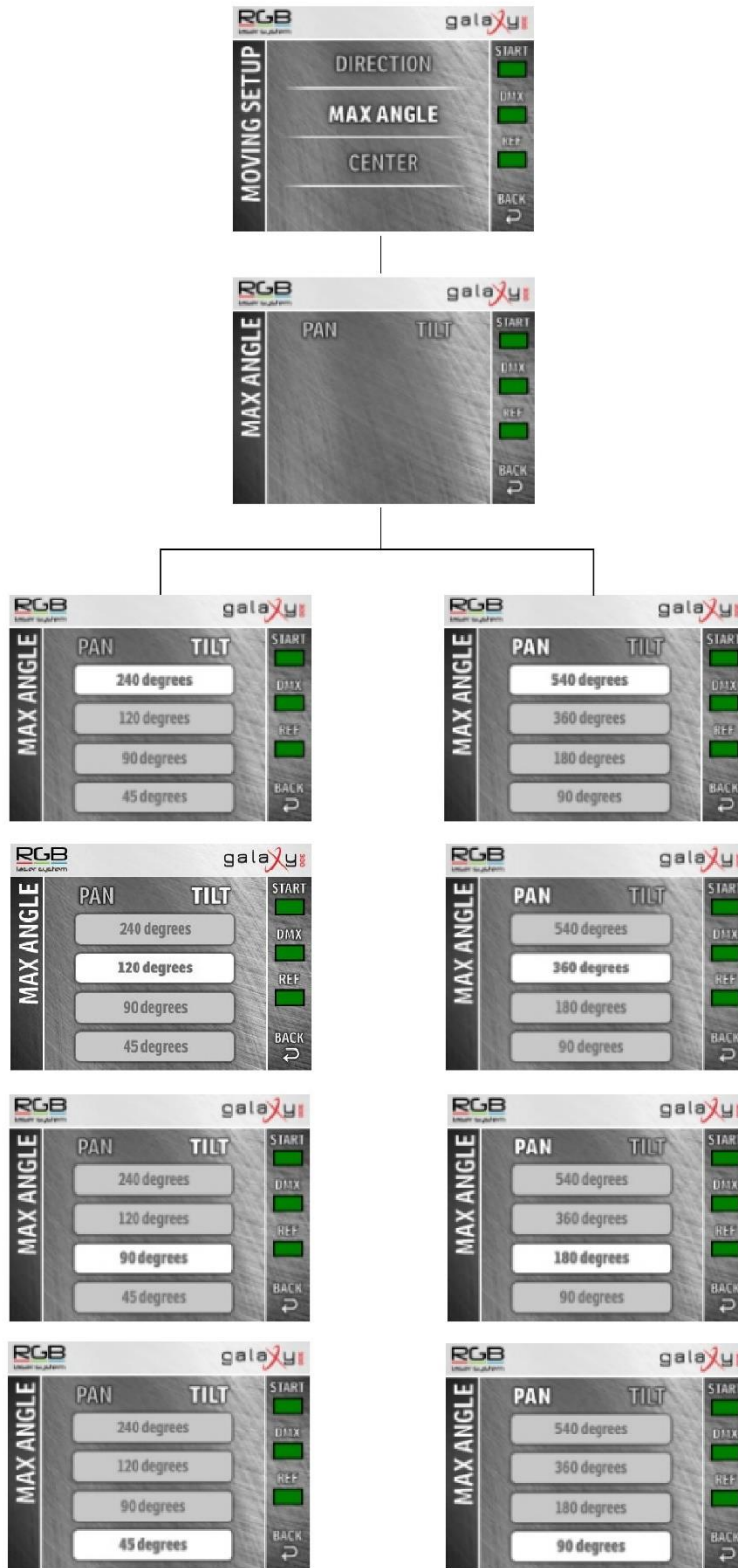

Center

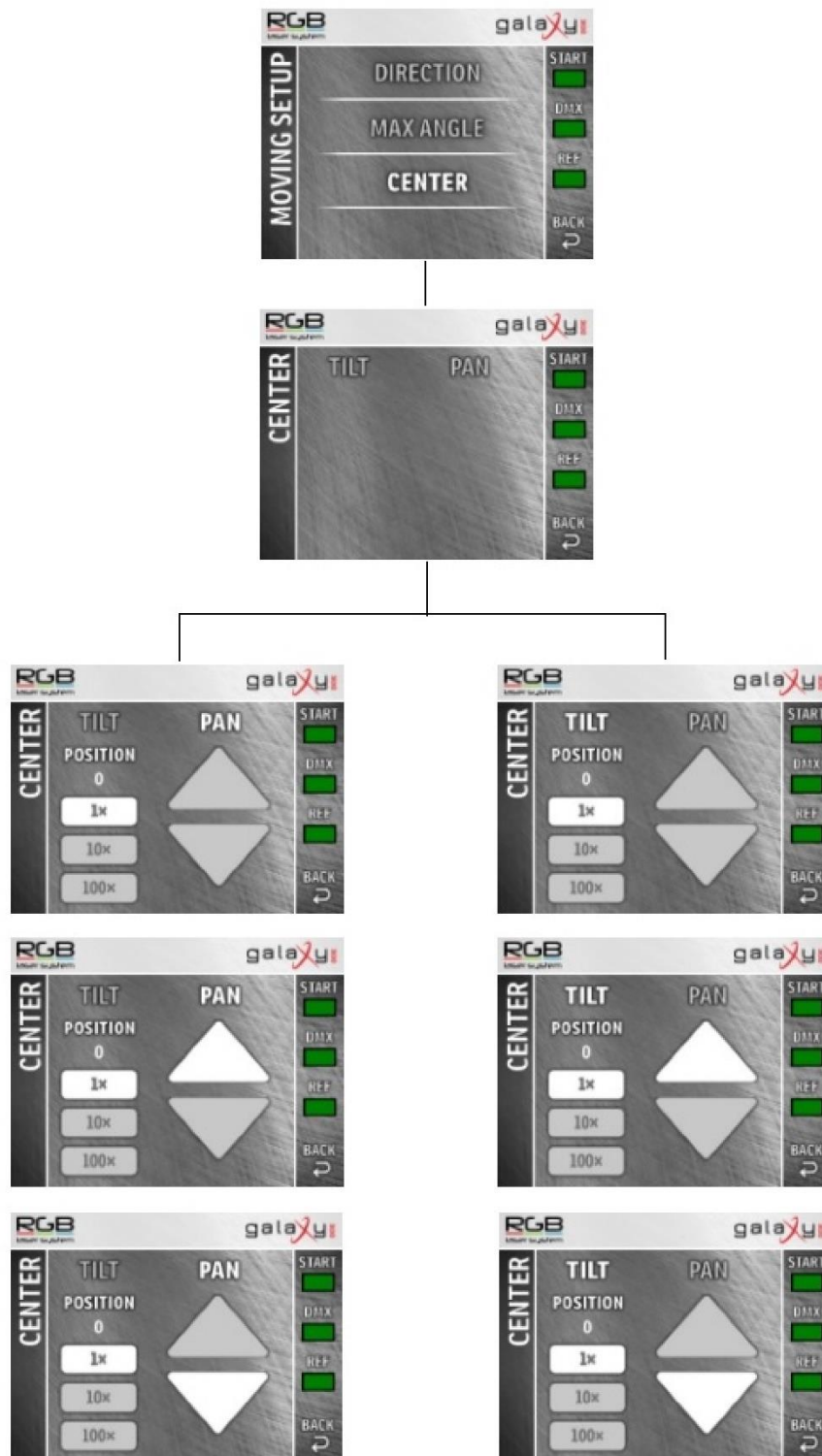

Control setup:

Here, you can configure the DMX Address, the Mode and the Display.

DMX Address



Mode

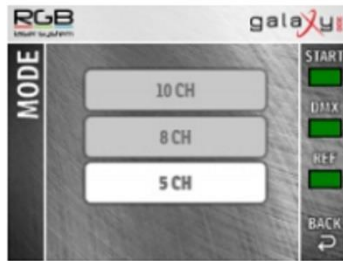
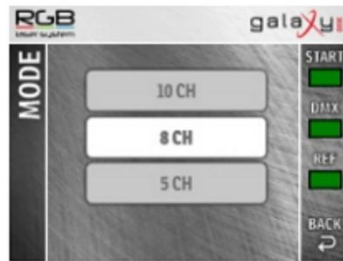

Display



Operating environment

The laser can only be used when the following conditions of the environment are given:

- Ambient temperature between +10C° and +35C°,
- Relative humidity max: 50% (at + 22C°),
- Below +10C° light intensity may decrease,
- Above +35C° operation may become unstable.

Storage: above +50C° permanent damage is likely to the device! (e.g.: do not leave it in your car in the summer, because in closed vehicles temperature may easily reach or exceed the maximum permitted level.)

Handling precautions

This laser system is a precision device that contains some sensitive opto-electronics components.

DO NOT drop it or subject it to physical shock.

This laser system is not waterproof or dust-proof. Make sure to use an appropriate cover or enclosure if it is used in the rain, snow or similar severe environment conditions.

There are apertures required for ventilation and airflow cooling on the top side of the device. It is PROHIBITED to obstruct or block any of the apertures preventing the free flow of air, because it may cause damages to the equipment.

Do not leave the laser system in excessive heat such as in a car whilst in direct sunlight. High temperatures could cause some serious damage to the system.

The laser system contains precision electronic circuitry. Never attempt to disassemble the laser yourself.

If the laser is suddenly brought in from the cold into a warm room, condensation may form on the laser and internal parts. If condensation forms on the laser body, do not use the laser as this may damage the laser system.

If there is condensation, wait until it has evaporated before using.



Maintenance

Aperture Window

To clean the aperture output window use a soft cloth and medical grade isopropyl alcohol.

Cooling Fans

Use compressed air for cleaning the bottom part of the laser system. There are cooling fans located at the bottom of the heat sink and they are vital for correct operation of the laser system. Please always ensure that they are spinning freely. You should perform this service every 2 months if the laser is used regularly or even more often if it is used in dusty conditions.

Internal Optics

The cleaning of the internal optical components should be performed by an authorized technician only. Incorrect techniques or wrong choice of chemicals used for cleaning could cause serious damage to the laser system. Due to the fact that the optical compartment is split and sealed from the rest of the laser system it shouldn't be necessary to perform this procedure more often than once a year.



Technical parameters

Output Power	100 mW	90 mW	100 mW
Wavelength	638 nm	520 nm	450 nm
Wavelength tolerance	+/- 5 nm	+/- 5 nm	+/- 5 nm
Beam mode	Single		
Beam diameter	3.3x2.3mm		
Beam divergence (full)	0.5 mRad		
Pan movement	540°		
Tilt movement	240°		
Speed	0,7 sec/360°		
Pan/Tilt resolution	16 bit		
Accuracy	2 mRad		
Power consumption	Continuous max. 20W		
Control	DMX		
Temperature of operation	10-35 Celsius		
Life of operation	5000 hours		
Supply voltage	90-240 V		
Size	Height	Width	Depth
	196,2mm	111,6mm	100mm
Weight	1,5 kg		



DMX protocol

Mode	Channel	Function	DMX value	Feature	Type of the control
1	1	Pan	0-255	0-540°	Proportional
	2	Pan fine	0-255	16-bit resolutions	Proportional
	3	Tilt	0-255	0-240°	Proportional
	4	Tilt fine	0-255	16-bit resolutions	Proportional
	5	Dimmer	0-255	0-100% brightness	Proportional
	6	Red	0-255	0-100% Red brightness	Proportional
	7	Green	0-255	0-100% Green brightness	Proportional
	8	Blue	0-255	0-100% Blue brightness	Proportional
	9	Strobe	000-003 004-251 252-255	Closed Slow 1/sec to Fast 12/sec Open	Proportional
	10	Functional	011-030 031-050 051-070 071-080 081-090 232-242	Fan OFF (standby) noise less Fan Auto Fan ON Display ON Display OFF Reset	Step
2	1	Pan	0-255	0-540°	Proportional
	2	Pan-fine	0-255	16- bit resolution	Proportional
	3	Tilt	0-255	0-240°	Proportional
	4	Tilt-fine	0-255	16-bit resolution	Proportional
	5	Dimmer	0-255	0-100% brightness	Proportional
	6	Red	0-255	0-100% Red brightness	Proportional
	7	Green	0-255	0-100% Green brightness	Proportional
	8	Blue	0-255	0-100% Blue brightness	Proportional
3	1	Pan	0-255	0-540°	Proportional
	2	Tilt	0-255	0-240°	Proportional
	3	Red	0-255	0-100% Red brightness	Proportional
	4	Green	0-255	0-100% Green brightness	Proportional
	5	Blue	0-255	0-100% Blue brightness	Proportional



List of parts



Warranty

We offer a warranty period of 12 months for the products starting from the date of delivery. This warranty is only valid if the system is used in conformity with the purpose it is designed for. The following are considered as improper use:

- Any type of usage different from the instructions in the operation manual.
- Opening the laser module.
- Exposing the product to adverse ambient conditions.
- Any strong mechanic impact.
- Any damage caused by a static discharge (in normal cases it must not happen).
- Use in a much polluted environment.

We reserve the right to decide if operation has not been proper and not in conformity with the conditions of warranty after the evaluation of the actual causes of the problem.

During the warranty period the obligation of Semiconductor Laser Development Ltd is restricted to the repair or replacement of the equipment returned to the maker with faults accepted by the maker (ones not caused by external reasons).

If any repair is done in the warranty period the time of warranty is not started again, but it continues from the date of delivery until the original date of expiry.

We are asking you to take warranty conditions into consideration and keep these documents available at a safe place. In case of needs copies are available from our records.

Semiconductor Laser Development Ltd





Made by: Semiconductor Laser Development Ltd

© All rights reserved.

RGB Laser and its logo are the official trademark of Semiconductor Laser Development Ltd

